

955 Series



## INSTALLATION MANUAL

LINEAR DISPLACEMENT TRANSDUCERS

# 955A BRIK

GEN III Analog LDT



Includes 955A  
Programming & Maintenance  
Instructions Plus Accessory Guide

**ABSOLUTE PROCESS CONTROL  
KNOW WHERE YOU ARE... REGARDLESS**



## Introduction

The **955A BRIK Gen III** is an accurate programmable, auto-tuning, non-contact, linear displacement transducer in an economical, low profile package. The transducer utilizes our field proven magnetostrictive technology to give absolute position, repeatable to .006% of the programmable sensing distance. The streamlined anodized aluminum extrusion houses the sensing element and electronics. The magnet moves over the sensing element that determines the position and converts it to an analog output. It can be ordered with a 0 to 10 VDC or 4 to 20mA output.

The **955A BRIK Gen III** has a few truly unique features. One feature is the LDT's auto-tuning capability, the ability to sense a magnet other than the standard slide magnet and adjust its signal strength accordingly. Another feature is that the analog output is programmable over the entire active stroke length. The active stroke area of the LDT lies between the Null and Dead zones.

There is a diagnostic LED located at the connector end of the probe that remains green while a good magnet signal is present and when the magnet is in the programmed stroke area. The LED turns yellow when the magnet is out of the programmed active range, but still within the active stroke area. The LED turns red and the output goes to 0 volts on voltage output units, or 4mA on current output units when there is no magnet present or when the magnet is out of the sensing area. The unit can easily be changed in the field from a 0 - 10VDC to a 10 - 0VDC or 4 - 20mA to a 20 - 4mA .

## Mounting

The transducer can be mounted vertically or horizontally using SD0522000 mounting brackets. The mounting brackets slide in the grooves on the lower part of the extrusion and clamp down when tightened. It is recommended to use one mounting bracket on each end and every three feet between.

Ferro-magnetic material, which is material readily magnetized, should be placed no closer than .25" from the sensing surface of the LDT.

## Floating Magnet Assembly

When using the Floating Magnet assembly SD0522100, the magnet should be installed within 3/8" of the sensing surface. The magnet assembly should also be installed in such a manner that it remains an even distance from the aluminum extrusion throughout the entire stroke. Improperly installed magnets can result in output signal non-linearity.

## LED Colors

**Green:** Magnet is present and within the active programmed range. **Red:** Fault, the LDT has lost its signal from the magnet or the magnet has moved into the Null or Dead zone. **Yellow:** The magnet is out of the programmed ZERO to SPAN range.

**Note 1:** ZERO or SPAN can be adjusted individually without setting the other. **Note 2:** ZERO = 0V on 0 to 10 VDC units and 4mA on 4 to 20mA units.

## Setting Zero & Span Positions

The 955A is programmable over the entire active stroke length of the LDT. Keep in mind that there is a 3" Null area at the connector end of the LDT and a 2.0" Dead area at the other end of the LDT that the magnet must stay out of at all times. The diagnostic LED can aid you in the setup of the Zero and Span. A green or yellow LED means that it is OK to program the LDT in this area, a red LED means that the LDT cannot be programmed in this area.

**To set the ZERO and SPAN position for the probe follow these steps.**

1. Power up the probe in normal operating mode (i.e. "PRGM" pin floating),
2. Place magnet assembly where ZERO is to be located, but within the active region of probe,
3. Momentarily short "PRGM" pin (pin 2) to ground (pin 3),
4. Place magnet assembly where SPAN is to be located, but within the active region of the probe,
5. Momentarily short "PRGM" pin (pin 2) to V+ (pin 1).

### Wiring Diagram 955A Only

#### Euro Connector (Micro 12 mm single keyway)

**Note:** Refer to your specific model number and application manual for the correct wire diagram and pin location.

Pin #	Wire Color	Function
1	Brown	Customer Supplied Power (+VDC)
2	White	Program Input
3	Blue	Power Supply Common
4	Black	Position Output
5	Gray	Analog Output Common

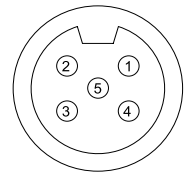

AMETEK Automation & Process Technologies has checked the accuracy of this manual at the time it was approved for printing. However, this manual may not provide all possible ways of installing and maintaining the LDT. Any errors found in this manual or additional possibilities to the installation and maintenance of the LDT will be added in subsequent editions. Any comments you have for the improvement of this manual are welcomed. AMETEK reserves the right to revise and redistribute the entire contents or selected pages of this manual. All rights to the contents of this manual are reserved by AMETEK.



Specifications	
Input Voltage	13.5 to 30 VDC
Current Draw	2.5 Watts Maximum, 120 mA @ 15 VDC Typical
Output	0 to 10 VDC 10 to 0 VDC 4 to 20 mA 20 to 4 mA
Resolution Internal Analog Output	0.001" 16 Bit (1 part in 65,535)
Non-Linearity	+/- 0.05% of Stroke
Repeatability	+/- 0.006% of Full Stroke
Update 40" or less 41" to 100" 101" to 150" 151" to 180"	1mS (Stroke Lengths 40" - 50") 2mS (Stroke Lengths 41" - 100") 3mS (Stroke Lengths 101" - 150") 4mS (Stroke Lengths 151" - 180")
Operating Temperature	-20° to 70° C
Span Length	5" to 180"
Null Zone	3.00"
Dead Zone	2.00"
LED	Green = Power is applied and magnet is present. Red = Fault, magnet is in the Dead Zone or lost Yellow = Out of the active programmed range
Connector	Standard 5 Pin Micro 12mm Euro Connector
Approvals	CE
Enclosure	IP67, Optional IP68
Specifications are subject to change without notice. Specifications are based on a typical 36" LDT.	

Accessories	
Item	Part Number
Slide Magnet	SD0521800
Float Magnet	SD0522100
Mounting Foot	SD0522000
6 Ft. Cable	949019L6
12 Ft. Cable	949019L12
6 Ft. Cable; Right Angle Connector	949020L6
12 Ft. Cable; Right Angle Connector	949020L12

Part Numbering			
<b>955A</b>	<b>XX</b>	<b>XXXX</b>	<b>X</b>
<b>955A BRIK with Analog Output</b>	<b>Stroke Length</b> Insert stroke in inches to 0.1 inch. Enter as a four-place number. Valid lengths are 0050 to 1800. <b>Example:</b> 12.0 inch probe stroke is entered as 0120. To convert a metric stroke in millimeters, multiply millimeter value by 0.03937 to arrive at inch value.		<b>Options</b> <b>X</b> = None
<b>Output</b> <b>V0</b> = 0 to 10 VDC <b>V1</b> = 10 to 0 VDC <b>C4</b> = 4 to 20mA <b>C2</b> = 20 to 4mA			

### Dimensions

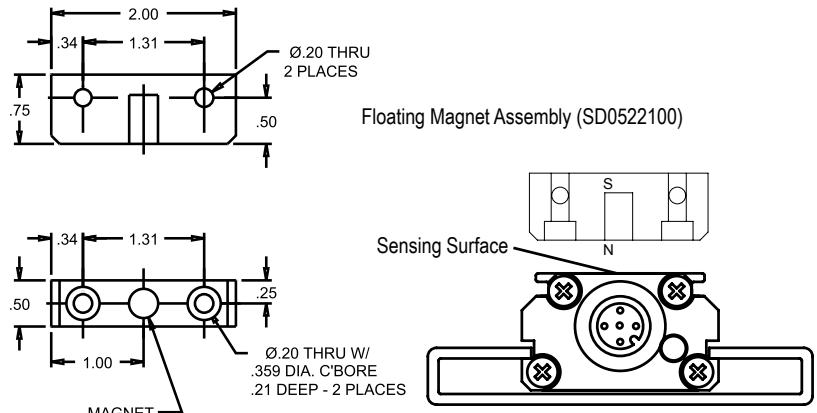

**NOTE:** The north pole of the magnet should be pointed towards the probe.

Mounting brackets (SD0522000) slide in the grooves on the side of the extruded housing. When tightened down with fastening hardware the mounting brackets clamp the unit into place. It is recommended to use one mounting bracket on each end and every three feet between.

A standard female swivel mounting arm is provided with the slide magnet assembly. For extensions and other options contact the factory.

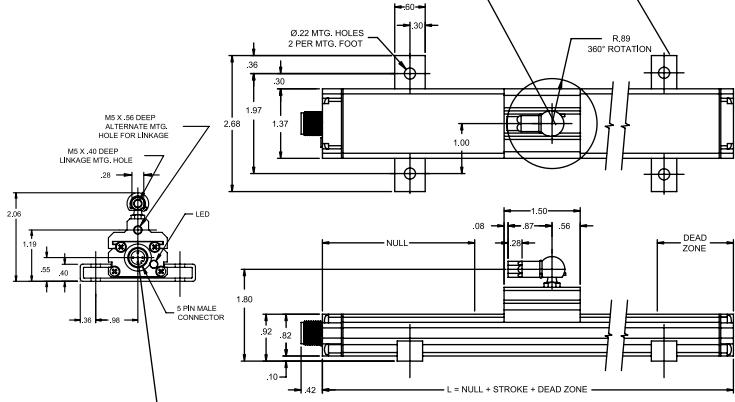

A standard 12 mm 5 pin micro connector is used. Straight mating cables can be ordered in a 6' length (949019L6), or 12' length (949019L12). If space is a consideration a right angle connector is also available, (949020L6 or 949020L12).

**\* WARNING: do not use cord sets with LED's**

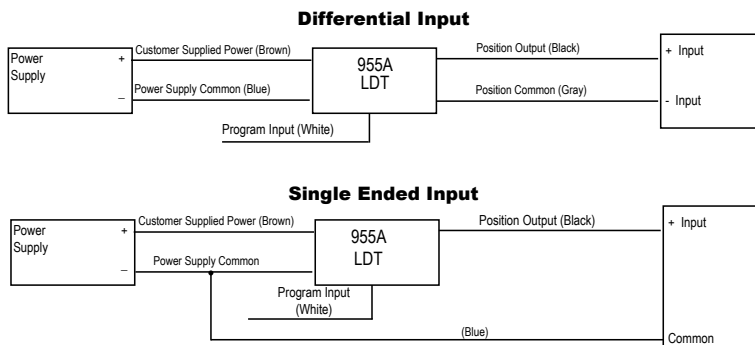

**Note:** 955A-C is current sourcing, which allows the current to flow from the LDT into the user's equipment.